

Important: Read All Instructions Prior to Installation

Function introduction

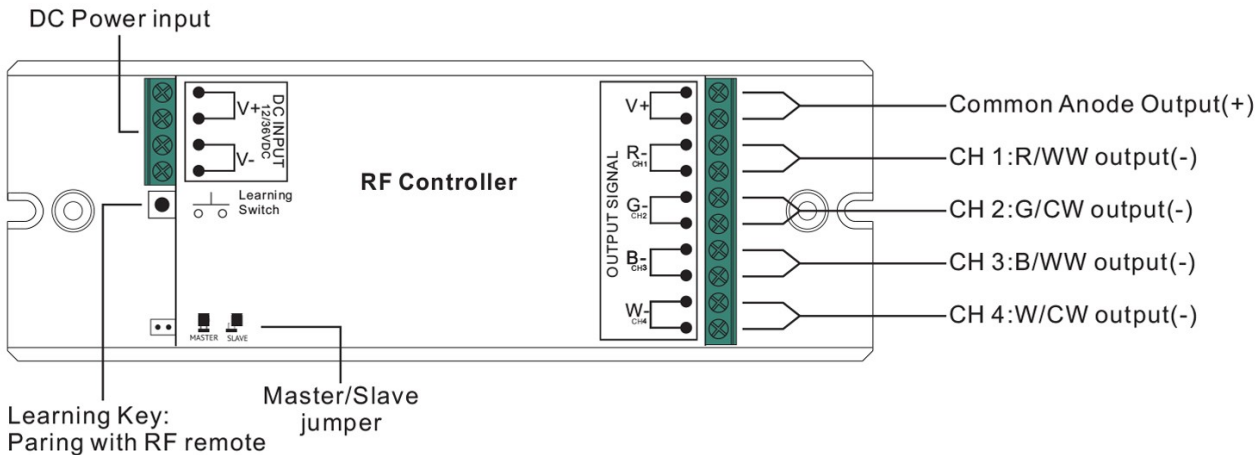

Product Data

Input Voltage	Output Current	Output Power	Remarks	Size(LxWxH)
12-36VDC	4x8A	4x(96-288)W	Constant voltage	170x59x29mm

- Radio Frequency : 868/915/434mhz
- Waterproof grade: IP20

Safety & Warnings

- DO NOT install with power applied to device.
- DO NOT expose the device to moisture.

Operation

Do wiring according to connection diagram.

Pair RF Receiver with RF remote:

1. Connect and wire up the RF receiver correctly, power on.
2. Turn on the remote, click the “**Learning Key**” button on receiver, immediately click a zone number to pair the receiver to the specified zone if the remote is a multi-zone controller (if it is a single zone remote, this step is unnecessary), then touch the color wheel or slider bar on the remote (if the remote does not have color wheel or slider bar, click or touch any keys), the connected led light on receiver flickers twice, which means well paired.

Note: one receiver can be paired with max 8 remote controls.

Delete the pairing:

1. Wire up the RF receiver correctly, power on.
2. Hold down the “**Learning Key**” button on receiver for over 3 seconds until the connected led light on receiver flickers twice, which means well deleted.

MASTER/SLAVE jumper:

In a group of multiple receivers, in order to get a good sync of RGB running effect, please set only 1 receiver as **MASTER**, the other receivers as **SLAVE**.

After setting the Master, the Master receiver need to power off and on once to make the Master function take effect.

Wiring Diagram

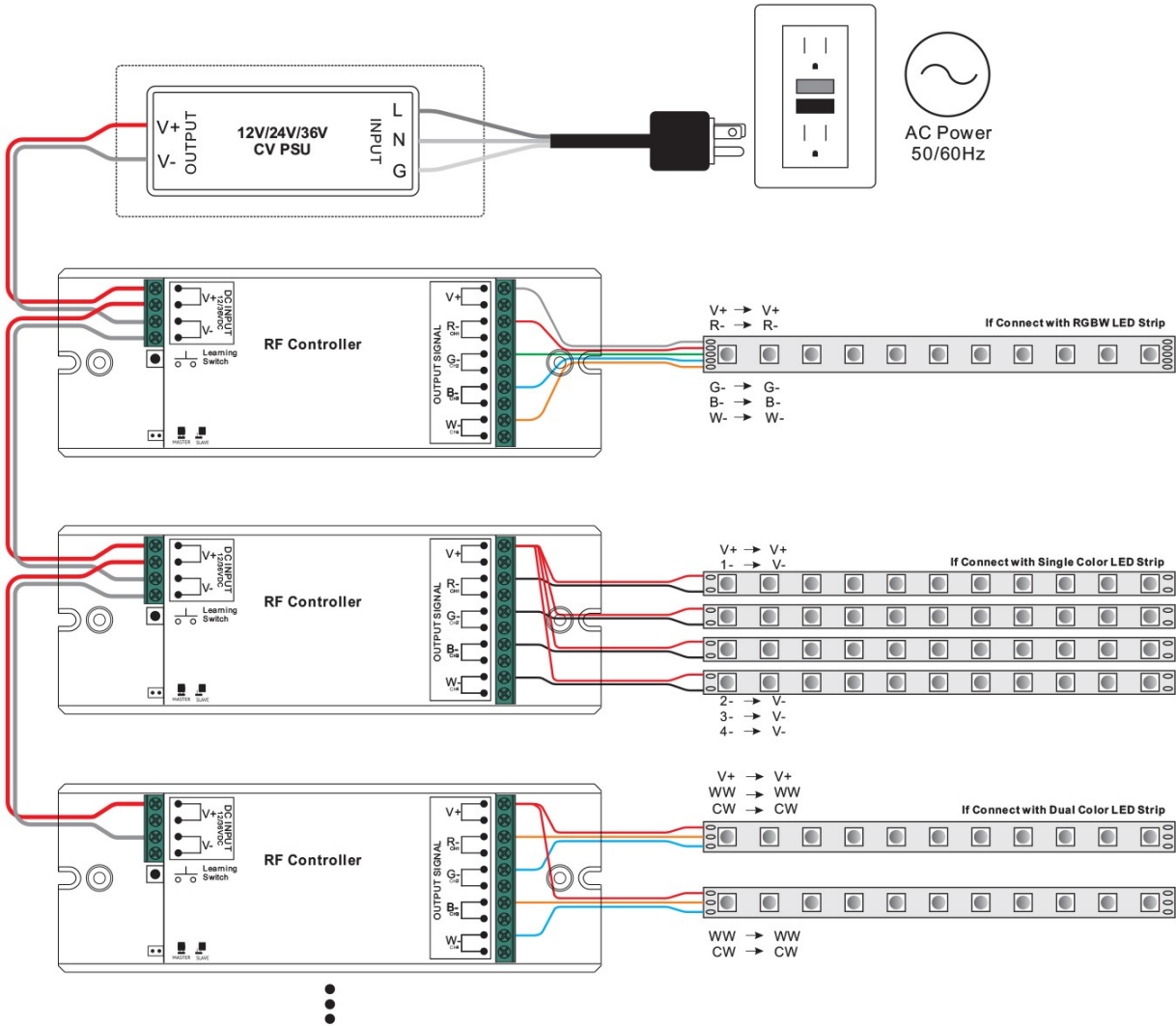

If you use multiple receivers, you have two choices:

Option 1: have all the receivers in the same zone, like zone 1

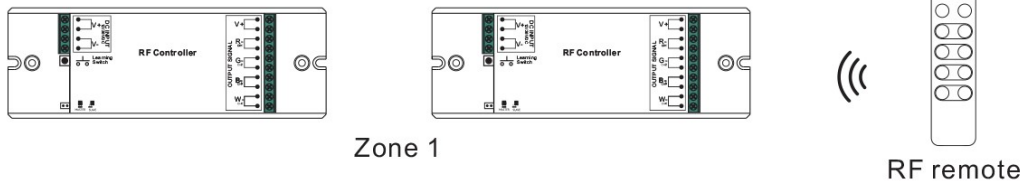

Option 2: have each receiver in a different zone, like zone 1, 2, 3 or 4

