

Project :	Date :
Cat. No :	Type :
Notes :	Volts :

**Description:**

The **NTALB-53** LED bar design provides a unique linear lighting solution combining style, performance and durability in a medium width strip, while reducing constructions and operating costs through installation time, energy savings and maintenance free application.

**Housing:**

The **NTALB-53** is a high precision extruded anodized aluminum that can accept a LED linear source from normal to high power. Each assembled Led Bar included two (2) aluminum end caps screwed.

**Lens:**

Precision fit extruded acrylic snap-in 180° diffusing lens available in:

**OP** Opal (white)

**Mounting:**

Mounts suspended

**CS** Suspension cables  
2 meters length (set of 2)

**Application/Installation:**

The **NTALB-53** LED bar can be suspended for 180° light diffusion with 2 suspension cables. Consult factory for damp application or splash area using our silicone jacketed IP67 sources. **(WP)**

**Voltage:**

12 VDC  
24 VDC

**Electrical and Electronics:**

High quality diodes tested (LM80) and certified life cycle for 60,000 hours (L80).

All certified electrical and electronic components have been re-tested over the years for compatibility within products and for specific applications. All products exceed current standards.

Power supply not included, consult factory. Consult the LED specification sheet for the appropriate optional dimmers and controls combination for your project.

**Homologation:**

Conforms to ANSI/UL standard UL-2108  
Certified to CAN/CSA standard 22.2-9.0



ENCAP



SUSPENSION CABLE



**Ordering Matrix / Specification**

Model	Bar	Length	Lens	Mounting	LED**	Color	Volts
NTALB	53	1000 mm 2000 mm XX mm*	OP Opal	CS Suspension Cable *	UT30 UT30 WP UT60 UT60 WP UT120 UT120 WP UT120 RGB+WH  HP30 HP30WP HP120 HP120WP  UT39K CCT (White)  RGB 150 RGB 150 WP  RGB 300 RGB 300 WP	VWW (2400K) WW (2700, 3000, 3500K) NW (4100K) WH (5000K) R (Red)*** B (Blue)*** G (Green)*** A (Amber)***  VWW (2400K) WW (3000K) NW (4100K) WH (5000K) R (Red)*** B (Blue)*** G (Green)*** A (Amber)***  (2700-6500K)****	12VDC 24VDC

\* Consult factory for special lengths.

\* remote driver only

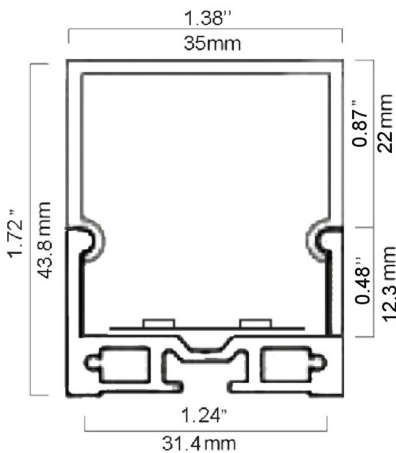

**Natech Industrie**

1995 Francis Hughes, Laval H7S 2G2 T: (450) 629-1169, F: (450) 629-1168, www.natechlighting.com, service@natechlighting.com

This specification is valid as of 2022-09 and is subject to change without notice. Please confirm with the manufacturer before placing an order. Copyright 2014 Natech Industrie. All rights reserved.

Project :

Date :

Cat. No :

Type :

Notes :

Volts :



ENCAP  
(REMOVEABLE)



SUSPENSION  
CABLE



### Natech Industrie

1995 Francis Hughes, Laval H7S 2G2 T: (450) 629-1169, F: (450) 629-1168, [www.natechlighting.com](http://www.natechlighting.com), [service@natechlighting.com](mailto:service@natechlighting.com)

This specification is valid as of 2022-09 and is subject to change without notice. Please confirm with the manufacturer before placing an order.  
Copyright 2014 Natech Industrie. All rights reserved.